

# Repair Parts

## Parts List for RIDGID 10" Compound Miter Saw Model No. MS1065LZ

RIDGID parts are available on-line at [www.ridgidparts.com](http://www.ridgidparts.com)

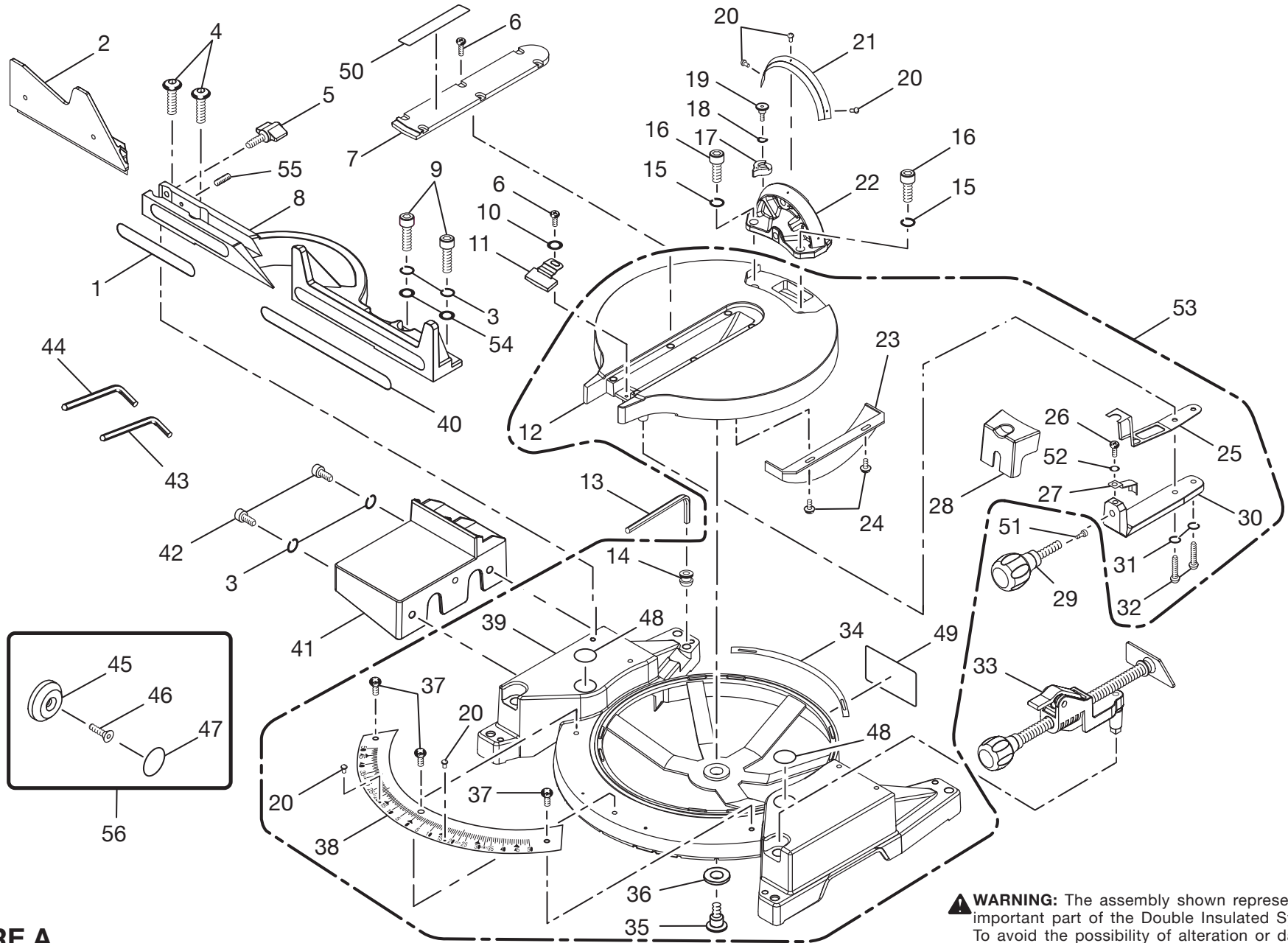

FIGURE A

**WARNING:** The assembly shown represents an important part of the Double Insulated System. To avoid the possibility of alteration or damage to the System, service should be performed by your nearest authorized service center.

# Repair Parts

## Parts List for RIDGID 10" Compound Miter Saw Model No. MS1065LZ

RIDGID parts are available on-line at [www.ridgidparts.com](http://www.ridgidparts.com)

### PARTS LIST FOR FIGURE A

Key No.	Part Number	Description	Quan.	Key No.	Part Number	Description	Quan.
1	503120000	LABEL .....	1	29	503105000	TABLE LOCK KNOB .....	1
2	503116100	SLIDING MITER FENCE.....	1	30	503110000	CONTROL ARM.....	1
3	A36070814200	SPRING WASHER (M8).....	4	31	A36070612150	SPRING WASHER (M6) .....	2
4	A08007080250	SCREW (M8 X 25L).....	2	32	A08007060250	SCREW (M6 X 25L).....	2
5	503117000	KNOB .....	1	33	503A07010	WORK CLAMP ASSEMBLY .....	1
6	A10007040100	SCREW (M4 X 10L) .....	7	34	503103000	WEAR STRIP .....	2
7	503114000	THROAT PLATE.....	1	35	503111000	TABLE SPINDLE .....	1
8	503115100	FENCE.....	1	36	503112000	WASHER.....	1
9	503122000	SCREW (M8 X 25L SOC. HD.) .....	2	37	A10007050105	SCREW (M5 X 10L) .....	5
10	A35070410010	FLAT WASHER (M4).....	1	38	503102000	MITER SCALE.....	1
11	503113000	MITER SCALE INDICATOR .....	1	39	503101100	MITER TABLE FRAME .....	1
12	503104100	MITER TABLE.....	1	40	503119000	LABEL.....	1
13	503121000	HEX KEY (5mm) .....	1	41	503502000	TABLE EXTENSION.....	1
14	503118000	HEX KEY HOLDER.....	1	42	A07007080150	SCREW (M8 X 15L SOC. HD.).....	2
15	A36071018250	SPRING WASHER (M10).....	2	43	A07910610000	HEX KEY (6mm).....	1
16	A07007100350	SCREW (M10 X 35L SOC. HD.) .....	2	44	A07910810000	HEX KEY (8mm).....	1
17	503209000	BEVEL ANGLE PIVOT .....	1	45	511504000	LASER GUIDE.....	1
18	A63020000040	O-RING.....	1	46	511505000	LASER GUIDE BOLT.....	1
19	503210000	FIXED SCREW.....	1	47	511514000	LASER WARNING LABEL.....	1
20	A49010020056	RIVET (2.5 X 5L) .....	5	48	588072000	HAND WARNING LABEL.....	2
21	503207000	BEVEL SCALE.....	1	49	503123000	DATA PLATE.....	1
22	503202000	BEVEL PIVOT BRACKET.....	1	50	503125000	INSERT WARNING LABEL.....	1
23	503106000	TABLE HOLD DOWN.....	1	51	503124000	PUSH TIP.....	1
24	A19007040090	SCREW (M4 X 9L) .....	2	52	A35070511150	FLAT WASHER.....	1
25	503107000	LOCK PLATE .....	1	53	S50300400	MITER TABLE ASSEMBLY .....	1
26	A10007050080	SCREW (M5 X 8L) .....	2	54	A35070816150	FLAT WASHER.....	2
27	503109000	SPRING PLATE .....	1	55	A18007040150	FIXED SCREW (M4 X 15L).....	1
28	503108000	SLEEVE .....	1	56	511D08010	LASER ASSEMBLY .....	1

# Repair Parts

## Parts List for RIDGID 10" Compound Miter Saw Model No. MS1065LZ

RIDGID parts are available on-line at [www.ridgidparts.com](http://www.ridgidparts.com)

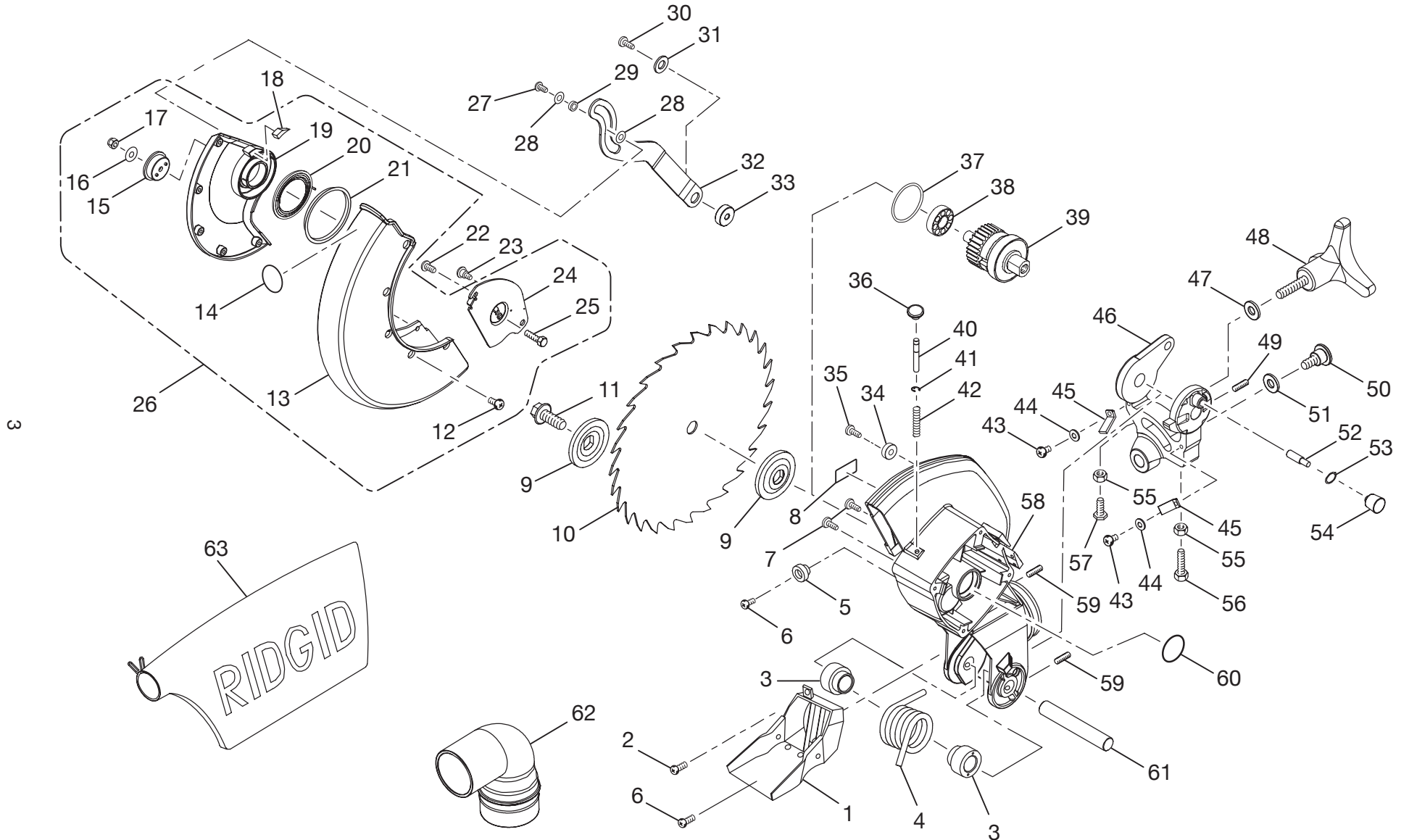

FIGURE B

**WARNING:** The assembly shown represents an important part of the Double Insulated System. To avoid the possibility of alteration or damage to the System, service should be performed by your nearest authorized service center.

# Repair Parts

## Parts List for RIDGID 10" Compound Miter Saw Model No. MS1065LZ

RIDGID parts are available on-line at [www.ridgidparts.com](http://www.ridgidparts.com)

### PARTS LIST FOR FIGURE B

Key No.	Part Number	Description	Quan.	Key No.	Part Number	Description	Quan.
1	503320100	DUST CHUTE .....	1	33	503411000	LINK WASHER.....	1
2	A16007050050	SCREW (M5 X 5L) .....	1	34	503304000	ROLLER .....	1
3	538327000	SPACER .....	2	35	503305000	SCREW .....	1
4	503319000	TORSION SPRING .....	1	36	503303000	SPINDLE KNOB (CAP).....	1
5	503306000	RUBBER SLEEVE.....	1	37	A63020000428	O-RING .....	1
6	A19007050120	SCREW (M5 X 10L) .....	2	38	A50060000027	BALL BEARING .....	1
7	588031004	FIXED SCREW.....	2	39	503A04010	ARBOR SHAFT ASSEMBLY (INC. 38) .....	1
8	503329000	UPPER ARM WARNING LABEL .....	1	40	503302000	SPINDLE LOCK PIN .....	1
9	588035105	FLANGE .....	2	41	A47000040006	E-RING .....	1
10	503501000	BLADE.....	1	42	588027005	COMPRESSION SPRING .....	1
11	503412000	SCREW .....	1	43	A10007040100	SCREW (M4 X 10L).....	2
12	503402000	T-SCREW .....	5	44	A35070406010	FLAT WASHER (M4).....	2
13	503401000	LOWER GUARD .....	1	45	503204000	INDICATOR .....	2
14	588072000	HAND WARNING LABEL .....	1	46	503201000	SUPPORT BRACKET .....	1
15	503407000	SPACER .....	1	47	A35071025150	FLAT WASHER (M10).....	1
16	A35070619150	FLAT WASHER (M6) .....	1	48	503203000	BEVEL LOCK KNOB .....	1
17	A31707006000	LOCK NUT (M6) .....	1	49	A18003040080	FIXED SCREW (M4 X 8L).....	1
18	503414000	SPONGE .....	1	50	503208000	PIVOT SHAFT .....	1
19	503403100	GUARD PLATE .....	1	51	589011308	WASHER.....	1
20	503406000	TENSION SPRING.....	1	52	503205000	STOP PIN.....	1
21	503413000	INNER PAD.....	1	53	A63000000062	O-RING .....	1
22	A19007050090	SCREW (M5 X 9L) .....	1	54	503206000	SPINDLE KNOB (CAP).....	1
23	503405000	SCREW .....	1	55	A30007006360	NUT (M6).....	2
24	503404100	BLADE BOLT COVER.....	1	56	A01007060160	BOLT (M6 X M16 HEX HD.).....	1
25	503415000	BOLT .....	1	57	503415000	BOLT .....	1
26	S50300300	LOWER GUARD ASSEMBLY .....	1	58	503301100	ARM .....	1
27	A10007050156	SCREW (M5 X 15L) .....	1	59	A18007060150	FIXED SCREW (M6 X 15L).....	2
28	503410000	WASHER .....	2	60	A63020000320	O-RING .....	1
29	A50010500020	BALL BEARING .....	1	61	503321000	SHAFT.....	1
30	A10007060200	SCREW (M6 X 20L) .....	1	62	503503000	DUST GUIDE .....	1
31	A35070619150	FLAT WASHER (M6) .....	1	63	503512000	DUST BAG.....	1
32	503408000	LINK ASSEMBLY.....	1				

# Repair Parts

## Parts List for RIDGID 10" Compound Miter Saw Model No. MS1065LZ

RIDGID parts are available on-line at [www.ridgidparts.com](http://www.ridgidparts.com)

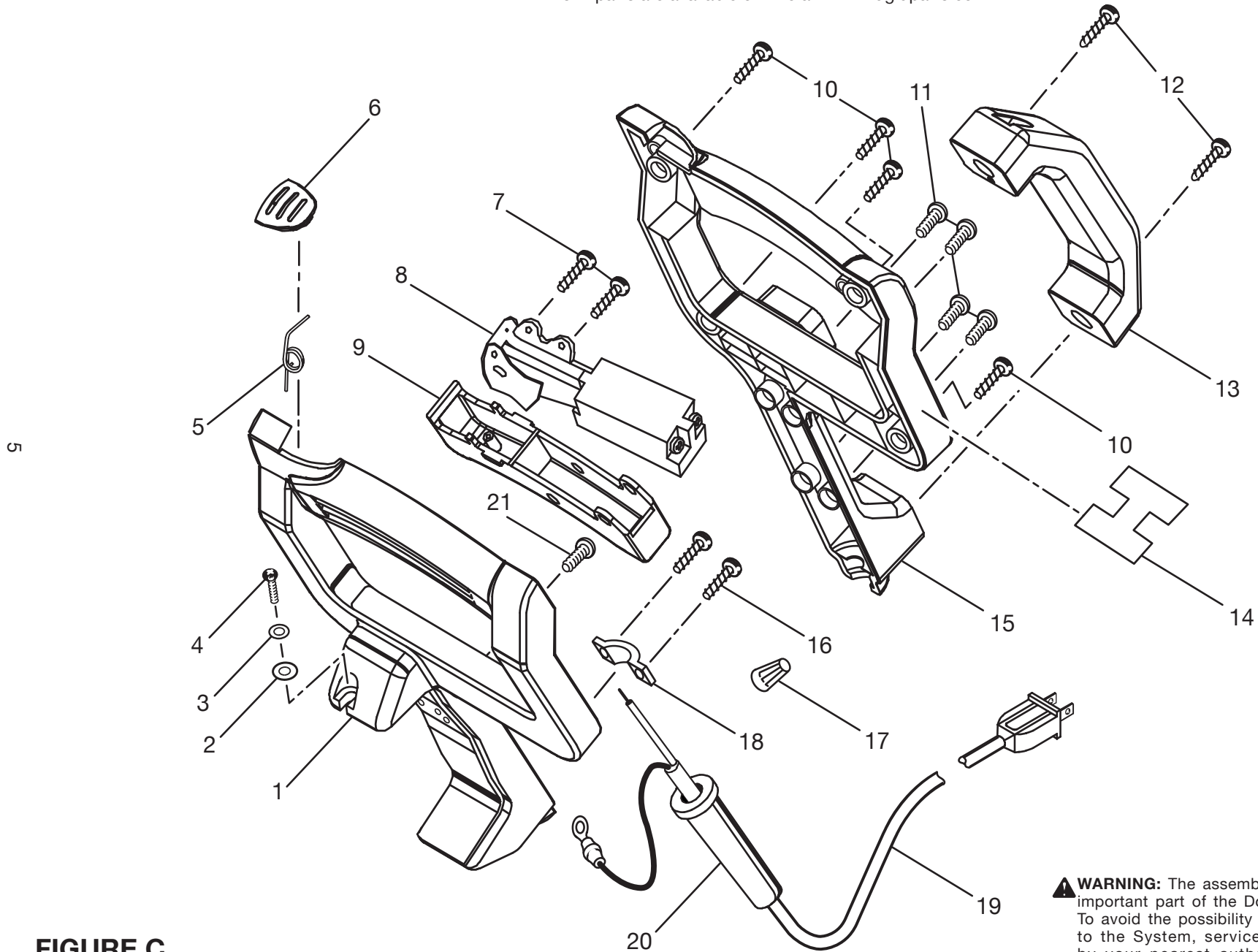

FIGURE C

**⚠ WARNING:** The assembly shown represents an important part of the Double Insulated System. To avoid the possibility of alteration or damage to the System, service should be performed by your nearest authorized service center.

# Repair Parts

## Parts List for RIDGID 10" Compound Miter Saw Model No. MS1065LZ

RIDGID parts are available on-line at [www.ridgidparts.com](http://www.ridgidparts.com)

### PARTS LIST FOR FIGURE C

Key No.	Part Number	Description	Quan.	Key No.	Part Number	Description	Quan.
1	503311000	LOWER HANDLE .....	1	12	A29007050200	SCREW (M5 X 20L) .....	2
2	A35070410010	FLAT WASHER (M4) .....	1	13	503315000	CARRYING HANDLE .....	1
3	A36070407010	SPRING WASHER (M4) .....	1	14	503326000	WARNING LABEL .....	1
4	A10007040120	SCREW (M4 X 12L) .....	1	15	503310000	UPPER HANDLE .....	1
5	503316000	SPRING .....	1	16	A90007040120	SCREW (M4 X 12L) .....	2
6	503314000	SAFETY BUTTON .....	1	17	503324000	ELECTRICAL NUT .....	1
7	A29007040080	SCREW (M4 X 8L) .....	2	18	578313006	CORD CLAMP .....	1
8	503317000	SWITCH .....	1	19	503318000	POWER CORD .....	1
9	503313000	TRIGGER .....	1	20	588004100	CORD BEND RELIEF .....	1
10	A29007040140	SCREW (M4 X 14L) .....	4	21	A10007050083	SCREW (M5 X 8L) .....	1
11	A19007050180	SCREW (M5 X 18L) .....	4				

# Repair Parts

## Parts List for RIDGID 10" Compound Miter Saw Model No. MS1065LZ

RIDGID parts are available on-line at [www.ridgidparts.com](http://www.ridgidparts.com)

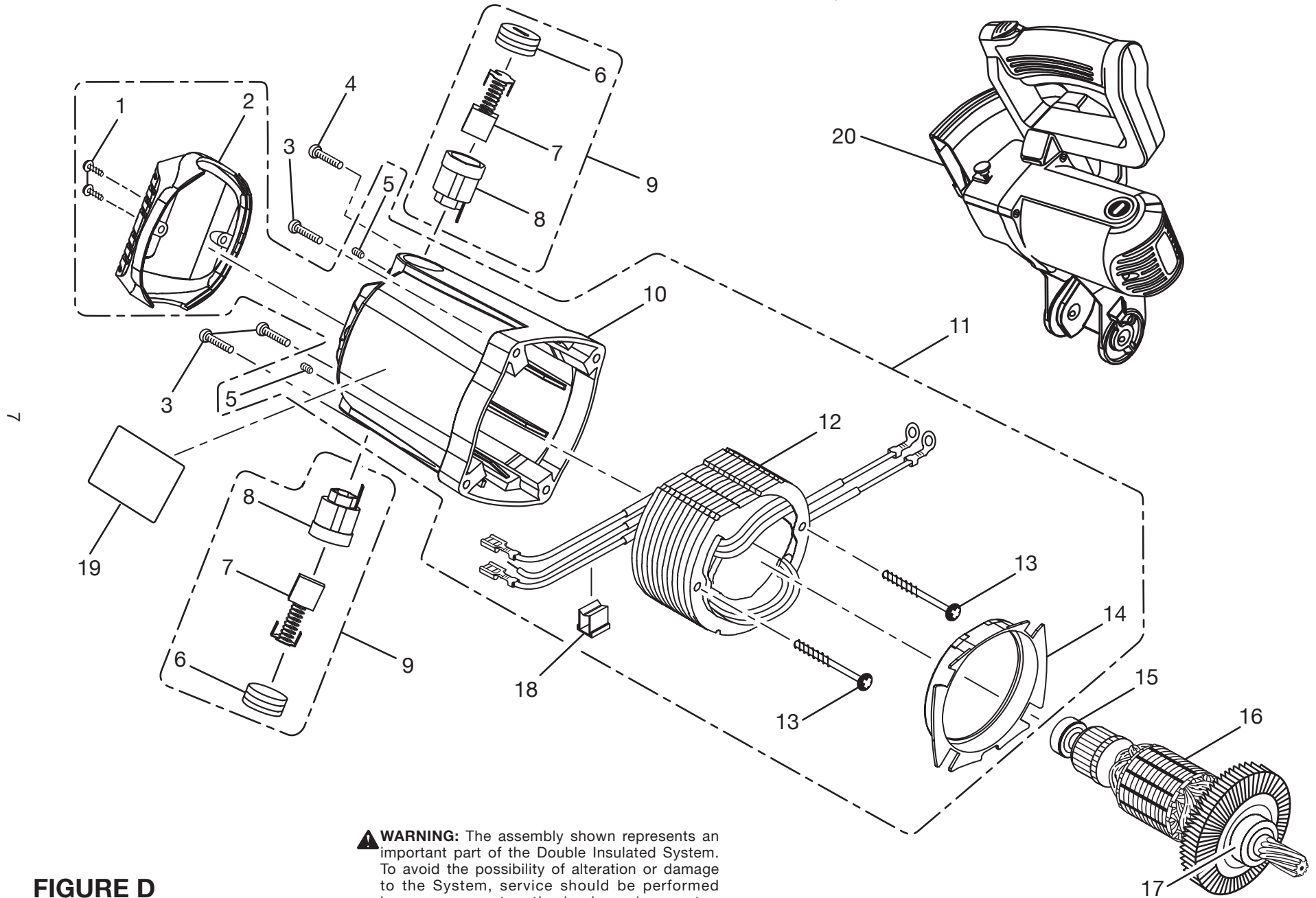

**WARNING:** The assembly shown represents an important part of the Double Insulated System. To avoid the possibility of alteration or damage to the System, service should be performed by your nearest authorized service center.

FIGURE D

# Repair Parts

## Parts List for RIDGID 10" Compound Miter Saw Model No. MS1065LZ

RIDGID parts are available on-line at [www.ridgidparts.com](http://www.ridgidparts.com)

### PARTS LIST FOR FIGURE D

Key No.	Part Number	Description	Quan.
1	A29007040080	SCREW (M4 X 8L) .....	2
2	503309000	END CAP .....	1
3	A19007050250	SCREW (M5 X 25L) .....	3
4	A19007050200	SCREW (M5 X 20L) .....	1
5	A18007050080	FIXED SCREW (M5 X 8L) .....	2
6	588005105	BRUSH CAP .....	2
7	588006100	BRUSH .....	2
8	588007300	BRUSH HOLDER .....	2
9	089036003700	BRUSH ASSEMBLY .....	2
10	503308000	MOTOR HOUSING.....	1

∞

Key No.	Part Number	Description	Quan.
11	S50300500	MOTOR HOUSING ASSEMBLY .....	1
12	9053D02000	FIELD ASSEMBLY .....	1
13	A90107050600	SCREW (M5 X 60L) .....	2
14	503312000	FAN CASING .....	1
15	A50060020056	BALL BEARING.....	1
16	9053C01000	ARMATURE ASSEMBLY (INC. # 15 & 17).....	1
17	A50006080049	BALL BEARING.....	1
18	503323000	LEAD SLEEVE .....	1
19	503328000	WARNING LABEL .....	1
20	S50300200	MOTOR ASSEMBLY.....	1
	983000234R 8-08-08	OPERATOR'S MANUAL (REV:02)	



## Parts List for RIDGID 10" Compound Miter Saw Model No. MS1065LZ

RIDGID parts are available on-line at [www.ridgidparts.com](http://www.ridgidparts.com)

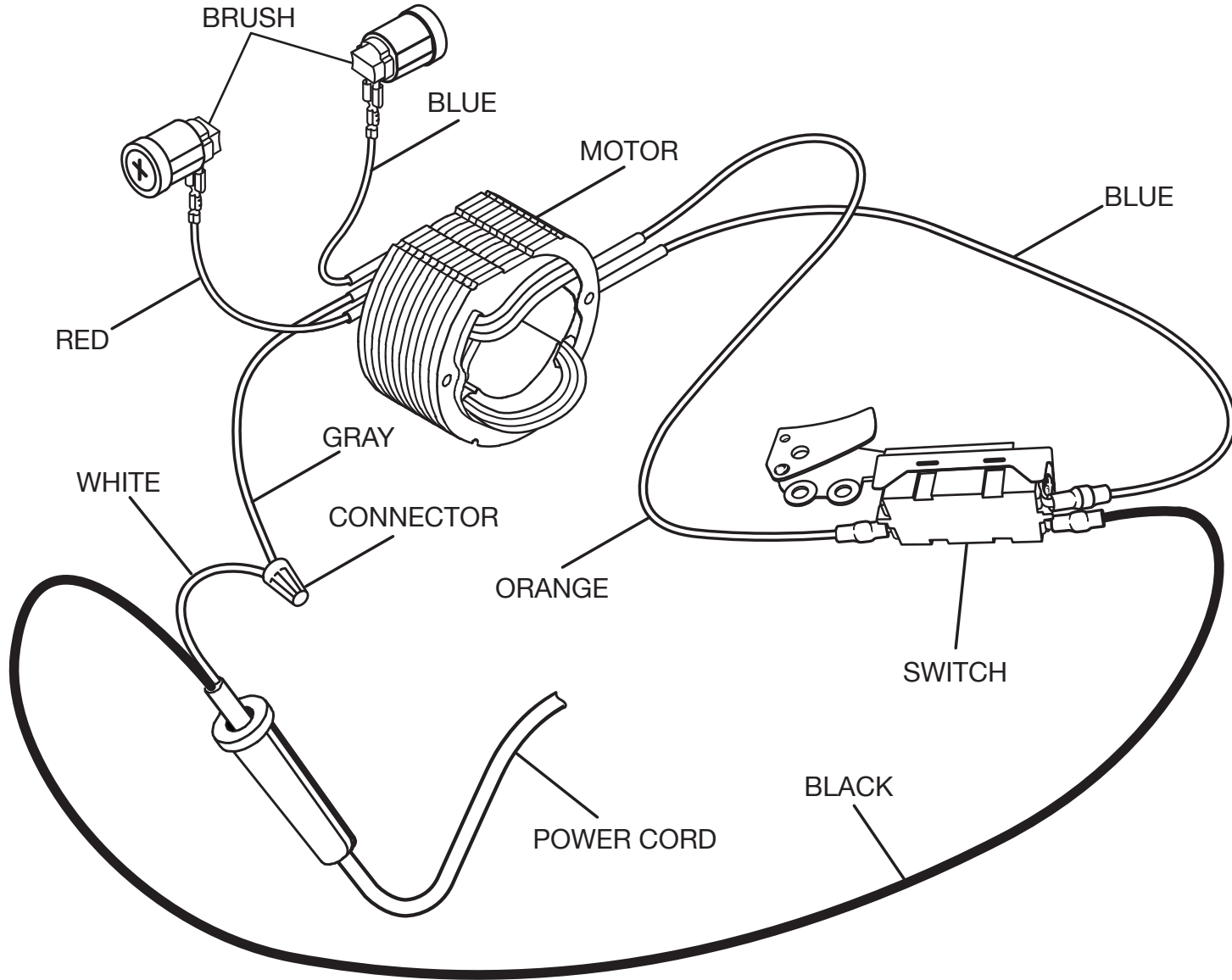

6

### WIRING DIAGRAM