

**RIDGID
FINISH STAPLER
MODEL NO. R150FSA
REPAIR SHEET**

**RIDGID
AGRAFEUSE DE FINITION
NO. DE MODÈLE R150FSA
FEUILLE DE RÉPARATION**

**RIDGID
GRAPADORA DE ACABADO
MODELO R150FSA
LISTAS DE PIEZAS DE REPUESTO**

RIDGID R150FSA

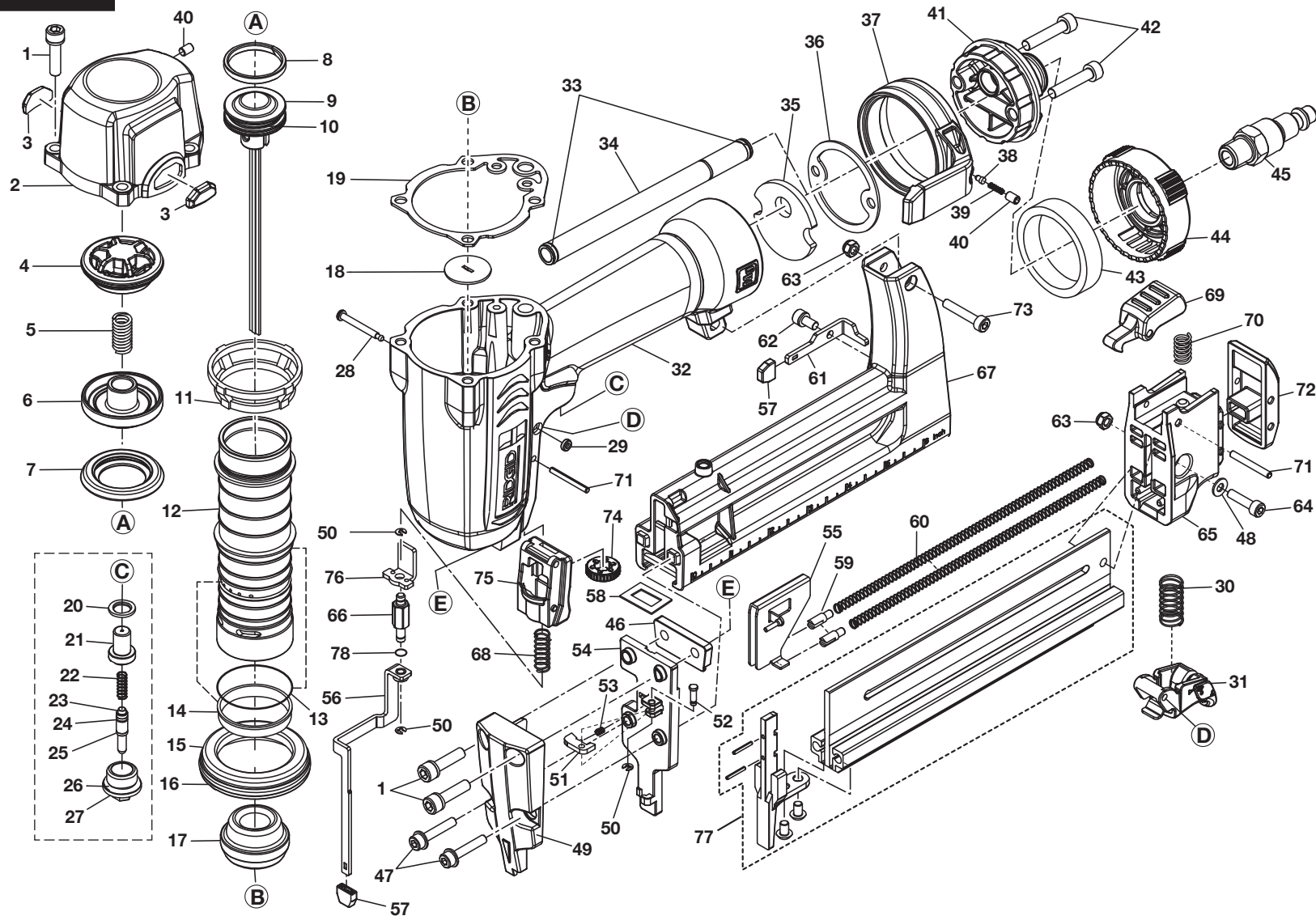

⚠ DANGER: Do not use oxygen, combustible gases, or bottled gases as a power source for this tool. The tool will explode and cause death or serious injury.

⚠ DANGER : Ne pas utiliser de l'oxygène ou des gaz combustibles ou en bouteille pour alimenter l'outil. L'outil exploserait, causant des blessures graves ou mortelles.

⚠ PELIGRO: No utilice oxígeno, gases combustibles ni gases embotellados como fuente de energía para esta herramienta. La herramienta explotará y causará la muerte o lesiones serias.

⚠ WARNING: Disconnect the tool from the air supply before performing maintenance. Failure to do so could result in serious personal injury.

⚠ AVERTISSEMENT : Débrancher l'outil de la source d'air avant tout entretien. Ne pas prendre cette précaution peut entraîner des blessures graves.

⚠ ADVERTENCIA: Desconecte la herramienta del suministro de aire antes de efectuar tareas de mantenimiento. La inobservancia de esta advertencia puede causar lesiones serias.



R150FSA Finish Stapler

KEY	P/N	DESCRIPTION	QTY	KEY	P/N	DESCRIPTION	QTY	KEY	P/N	DESCRIPTION	QTY
1	079001001001	BOLT ASSY (M5 x 0.8-20 + Dp5) ..	6	42	079001001043	BOLT (HEX SOC. HD.) (M5 x 0.8-25) ..	2	76	079001001078	WORK CONTACT ELEMENT	1
2	079001001002	CAP	1	43	079001001044	MUFFLER	1	77	079001001705	* MAGAZINE AND DRIVER GUIDE ASSEMBLY	1
3	079001001003	GUIDE COVER	2	44	079001001045	GUIDE PLATE	1	78	079007001116	O-RING	1
4	079001001004	COLLAR	1	45	079001001046	AIR PLUG (NPT 1/4 in.-18)	1	79	079001001082	OVERHAUL KIT – NOT SHOWN (INCL. KEY NO. 4, 7, 8, 13, 14, 16, 17, 19, 20-27, AND 29, PLUS LUBRICANT)	1
5	079001001005	COMPRESSION SPRING	1	46	079001001047	GASKET	1	80	079007001183	DRIVER MAINTENANCE KIT – NOT SHOWN (INCL. KEY NO. 8-10, 17 AND 19, PLUS LUBRICANT)	1
6	079001001006	HD.VALVE PISTON	1	47	079001001048	BOLT W/FLAT WASHER (M4 x 0.7-22 + Dp9 x t0.8) (3M23)	2	81	079007001184	DRIVER ASSEMBLY – NOT SHOWN (INCL. KEY NO. 8-10 PLUS LUBRICANT)	1
7	079001001007	SEAL	1	48	079001001049	FLAT WASHER (D9 x d4.2 x t0.8)	1	82	079001001085	TRIGGER ASSEMBLY – NOT SHOWN (INCL. KEY NO. 20-27) ...	1
8	079001001008	PISTON RING	1	49	079001001050	RELIEF PLATE	1	83	079001001099	WRENCH KIT – NOT SHOWN (INCL. 3 mm AND 4 mm HEX KEYS)	1
9	079007001009	DRIVER UNIT	1	50	079001001051	E-RING (ETW2)	3	84	079001001907	TOOL BAG – NOT SHOWN	1
10	079001001010	O-RING (23 x 2) (2023)	1	51	079001001052	WORK CONTACT ELEMENT DAMPER	1	85	079001001088	GLASSES – NOT SHOWN	1
11	079001001011	COLLAR	1	52	079001001053	FIXED PIN	1	86	079001001096	WARNING LABEL – NOT SHOWN	1
12	079001001012	CYLINDER	1	53	079001001054	POSITIONING SPRING	1	87	079001001095	DATA LABEL – NOT SHOWN	1
13	079001001013	O-RING (32 x 2) (2032)	1	54	079001001055	DRIVER GUIDE COVER	1	88	079001001092	LOGO LABEL – NOT SHOWN	2
14	079001001014	CYLINDER RING	1	55	079001001059	PUSHER UNIT	1	89	079001001093	MODEL LABEL (TOOL CASE)	1
15	079001001015	CYLINDER SPACER	1	56	079001001081	CONTACT MECHANISM A	1	90	983000614	OPERATOR'S MANUAL – NOT SHOWN	1
16	079001001016	O-RING (47.5 x 2) (S48)	1	57	079001001090	NO MAR PAD	2	91	983000623	FASTENER GUIDE – NOT SHOWN	1
17	079001001017	BUMPER	1	58	079001001130	* JOINT GUIDE	1	92	079001001102	TRIGGER WRAP LABEL – NOT SHOWN	1
18	079001001129	* DRIVER GUIDE	1	59	079001001060	SHAFT	2	93	079001001103	HANG TAG – NOT SHOWN	1
19	079001001019	CYLINDER CAP SEAL	1	60	079001001061	PUSHER SPRING	2				
20	079001001020	SEAL	1	61	079001001062	STOPPER	1				
21	079001001021	TRIGGER VALVE HEAD	1	62	079001001063	BOLT ASSY (M4 x 0.7-08 + Dp4)	1				
22	079001001022	SPRING	1	63	079001001064	LOCK NUT (M4 x 0.7)	2				
23	079001001023	PLUNGER	1	64	079001001065	BOLT (HEX SOC. HD.) (M4 x 0.7-16)	1				
24	079001001024	O-RING (2.5 x 1.5) (S3)	1	65	079001001066	REAR PLATE	1				
25	079001001025	O-RING (2.5 x 1.5) (S3)	1	66	079001001079	ADJUST ROD UNIT	1				
26	079001001026	O-RING (13 x 2) (2013)	1	67	079001001105	MAGAZINE UNIT B W/INSERTS ..	1				
27	079001001027	PLUNGER CAP	1	68	079001001077	WORK CONTACT ELEMENT SPRING	1				
28	079001001028	TRIGGER PIVOT PIN	1	69	079001001070	LATCH	1				
29	079001001029	RETAINER	1	70	079001001071	LOCK SPRING	1				
30	079001001030	SPRING	1	71	079001001072	SPIRAL PINS (Dp3-24)	2				
31	079001001031	TRIGGER UNIT	1	72	079001001073	HOOD COVER	1				
32	079007001701	* TOOL BODY UNIT	1	73	079001001074	BOLT (HEX SOC. HD.) (M4 x 0.7-25)	1				
33	079001001033	O-RING (7.5 x 1.5) (S8)	2	74	079007001115	ADJUST KNOB	1				
34	079001001034	LINK ROD	1	75	079001001076	WORK CONTACT ELEMENT GUIDE	1				
35	079001001036	FILTER	1								
36	079001001037	GASKET	1								
37	079001001038	SPRING RETAINER	1								
38	079001001039	POSITIONING SHAFT	1								
39	079001001040	POSITIONING SPRING	1								
40	079001001041	SCREW (HEX SOC. HD.) (M4 x 0.7-06)	2								
41	079001001042	END CAP (NPT 1/4 in.)	1								

* Note: Changes start with serial number:
AW082815576

3-6-13
(REV:09)



R150FSA Agrafeuse de finition

CLÉ	RÉF.	DESCRIPTION	QTÉ	CLÉ	RÉF.	DESCRIPTION	QTÉ	CLÉ	RÉF.	DESCRIPTION	QTÉ
1	079001001001	BOULON (M5 x 0,8-20 + Dp5).....	6	42	079001001043	BOULON (6 PANS, TÊTE CREUSE) (M5 x 0,8-25).....	2	75	079001001076	GUIDE DU DISPOSITIF DE DÉCLENCHEMENT PAR CONTACT	1
2	079001001002	COUVERCLE.....	1	43	079001001044	SILENCIEUX.....	1	76	079001001078	DISPOSITIF DE DÉCLENCHEMENT PAR CONTACT.....	1
3	079001001003	COUVERCLE DU GUIDE	2	44	079001001045	PLAQUE DU GUIDE.....	1	77	079001001705	* MAGASIN ET MÉCANISME D ENTRAÎNEMENT.....	1
4	079001001004	COLLIER	1	45	079001001046	BOUCHON D'AIR (NPT 1/4 po-18).....	1	78	079007001116	JOINT TORIQUE	1
5	079001001005	RESSORT DE COMPRESSION.....	1	46	079001001047	JOINT	1	79	079001001082	KIT D'ENTRETIEN DE REMISE À NEUF – PAS ILLUSTRÉ (INCLUT PIÈCES DE REPÈRE 4, 7, 8, 13, 14, 16, 17, 19, 20 À 27, ET 29, PLUS LE LUBRIFIANT).....	1
6	079001001006	PISTON DE SOUPE.....	1	47	079001001048	BOULON AVEC RONDELLE PLATE (M4 x 0,7-22 + Dp9 x t0,8) (3M23).....	2	80	079007001183	KIT D'ENTRETIEN DU MÉCANISME D'ENTRAÎNEMENT – PAS ILLUSTRÉ (INCLUT PIÈCES DE REPÈRE 8 À 10, 17, ET 19, PLUS LE LUBRIFIANT).....	1
7	079001001007	JOINT	1	48	079001001049	RONDELLE PLATE (D9 x d4,2 x t0,8)	1	81	079007001184	MÉCANISME D'ENTRAÎNEMENT – PAS ILLUSTRÉ (INCLUT PIÈCES DE REPÈRE 8 À 10 PLUS LE LUBRIFIANT).....	1
8	079001001008	SEGMENT DE PISTON	1	49	079001001050	PLAQUE DE SOULAGEMENT	1	82	079001001085	GÂCHETTE – PAS ILLUSTRÉ (INCLUT PIÈCES DE REPÈRE 20 À 27).....	1
9	079007001009	ENTRAÎNEMENT	1	50	079001001051	CLIP EN E (ETW2).....	3	83	079001001099	ENSEMBLE CLÉ – PAS ILLUSTRÉ (INCLUT LES CLÉS HEXAGONALES DE 3 ET 4 mm UNIQUEMENT).....	1
10	079001001010	JOINT TORIQUE (23 x 2) (2023).....	1	51	079001001052	AMORTISSEUR DU DISPOSITIF DE DÉCLENCHEMENT PAR CONTACT	1	84	079001001907	SACOCHE – PAS ILLUSTRÉ.....	1
11	079001001011	COLLIER	1	52	079001001053	AXE FIXE	1	85	079001001088	LUNETTES – PAS ILLUSTRÉ.....	1
12	079001001012	CYLINDRE.....	1	53	079001001054	RESSORT DE POSITIONNEMENT.....	1	86	079001001096	AUTOCOLLANT D'AVERTISSEMENT – PAS ILLUSTRÉ.....	1
13	079001001013	JOINT TORIQUE (32 x 2) (2032).....	1	54	079001001055	COUVERCLE DE GUIDE D'ENTRAÎNEMENT	1	87	079001001095	AUTOCOLLANT SIGNALÉTIQUE – PAS ILLUSTRÉ.....	1
14	079001001014	BAGUE DE CYLINDRE.....	1	55	079001001059	POUSOIR.....	1	88	079001001092	PLAQUETTE DE LOGO – PAS ILLUSTRÉE.....	2
15	079001001015	PIÈCE D'ÉCARTEMENT.....	1	56	079001001081	MÉCANISME DE CONTACT A.....	1	89	079001001093	PLAQUETTE MODÈLE (COFFRET).....	1
16	079001001016	JOINT TORIQUE (47,5 x 2) (S48)	1	57	079001001090	COUSSINET DE PROTECTION.....	2	90	983000614	MANUEL D'UTILISATION – PAS ILLUSTRÉ.....	1
17	079001001017	BUTOIR	1	58	079001001130	* GUIDE D'ASSEMBLAGE.....	1	91	983000623	GUIDE – PAS ILLUSTRÉ.....	1
18	079001001129	* GUIDE D'ENTRAÎNEMENT	1	59	079001001060	ARBRE	1	92	079001001102	AUTOCOLLANT DE GÂCHETTE – PAS ILLUSTRÉ.....	1
19	079001001019	JOINT DU COUVERCLE DE CYLINDRE.....	1	60	079001001061	RESSORT DE POUSSOIR.....	2	93	079001001103	ÉTIQUETTE – PAS ILLUSTRÉ.....	1
20	079001001020	JOINT	1	61	079001001062	BUTÉE.....	1				
21	079001001021	TÊTE DE SOUPE DE GÂCHETTE.....	1	62	079001001063	BOULON (M4 x 0,7-08 + Dp4)	1				
22	079001001022	RESSORT.....	1	63	079001001064	ÉCROU DE BLOCAGE (M4 x 0,7).....	2				
23	079001001023	PLONGEUR.....	1	64	079001001065	BOULON (6 PANS, TÊTE CREUSE) (M4 x 0,7-16).....	1				
24	079001001024	JOINT TORIQUE (2,5 x 1,5) (S3)	1	65	079001001066	PLAQUE ARRIÈRE	1				
25	079001001025	JOINT TORIQUE (2,5 x 1,5) (S3)	1	66	079001001079	TIGE DE RÉGLAGE.....	1				
26	079001001026	JOINT TORIQUE (13 x 2) (2013).....	1	67	079001001105	DISPOSITIF DU MÉCANISME DECONTACT B AVEC INSERTS	1				
27	079001001027	COUVERCLE DU PLONGEUR.....	1	68	079001001077	RESSORT DU DISPOSITIF DE DÉCLENCHEMENT PAR CONTACT	1				
28	079001001028	AXE PIVOT DE GÂCHETTE.....	1	69	079001001070	LOQUET	1				
29	079001001029	RETENUE.....	1	70	079001001071	RESSORT DE VERROUILLAGE	1				
30	079001001030	RESSORT.....	1	71	079001001072	GOUPILLES SPIRALES (Dp3-24).....	2				
31	079001001031	GÂCHETTE.....	1	72	079001001073	CAPOTAGE DE PROTECTION.....	1				
32	079007001701	* CORPS DE L'OUTIL.....	1	73	079001001074	BOULON (6 PANS, TÊTE CREUSE) (M4 x 0,7-25).....	1				
33	079001001033	JOINT TORIQUE (7,5 x 1,5) (S8)	2	74	079007001115	BOUTON DE RÉGLAGE.....	1				
34	079001001034	BIELLE.....	1								
35	079001001036	ÉLÉMENT FILTRANT.....	1								
36	079001001037	JOINT	1								
37	079001001038	RETENUE DE RESSORT.....	1								
38	079001001039	AXE DE POSITIONNEMENT	1								
39	079001001040	RESSORT DE POSITIONNEMENT	1								
40	079001001041	VIS (6 PANS, TÊTE CREUSE) (M4 x 0,7-06).....	2								
41	079001001042	CAPUCHON D'EXTRÉMITÉ (NPT 1/4 po).....	1								

* **Note: Commencer avec le numero de série:
AW082815576**



R150FSA - Grapadora de Acabado

REF.	N/P	DESCRIPCIÓN	CANT.	REF.	N/P	DESCRIPCIÓN	CANT.	REF.	N/P	DESCRIPCIÓN	CANT.
1	079001001001	CONJ. DEL PERNO (M5 x 0,8-20 + Dp5)	6	42	079001001043	PERNO (CAB. HUE. HEX) (M5 x 0,8-25)	2	75	079001001076	GUÍA DEL ELEMENTO DE CONTACTO CON LA PIEZA DE TRABAJO	1
2	079001001002	TAPA	1	43	079001001044	SILENCIADOR	1	76	079001001078	ELEMENTO DE CONTACTO CON LA PIEZA DE TRABAJO	1
3	079001001003	TAPA DE LA GUÍA	2	44	079001001045	PLACA DE LA GUÍA	1	77	079001001705	* CARGADOR Y CONJUNTO DEL IMPULSOR	1
4	079001001004	COLLAR	1	45	079001001046	TAPÓN DEL AIRE (NPT 1/4 pulg.-18)	1	78	079007001116	JUNTA TÓRICA	1
5	079001001005	RESORTE COMPRESIÓN	1	46	079001001047	JUNTA	1	79	079001001082	JUEGO DE MANTENIMIENTO GENERAL – NO SE MUESTRA (INCL. LLAVES NÚM. 4, 7, 8, 13, 14, 16, 17, 19, 20-27, Y 29, Y LUBRICANTE)	1
6	079001001006	PISTÓN VÁLVULA CAB	1	47	079001001048	PERNO C/ ARANDELA PLANA (M4 x 0,7-22 + Dp9 x t0,8) (3M23)	2	80	079007001183	JUEGO DE MANTENIMIENTO DEL SISTEMA IMPULSOR – NO SE ILUSTR (INCL. LLAVES NÚM. 8-10, 17, Y 19, Y LUBRICANTE)	1
7	079001001007	SELLO	1	48	079001001049	ARANDELA PLANA (D9 x d4,2 x t0,8)	1	81	079007001184	CONJUNTO DEL IMPULSOR – NO SE ILUSTR (INCL. LLAVES NÚM. 8-10 Y LUBRICANTE)	1
8	079001001008	ANILLO DEL PISTÓN	1	49	079001001050	PLACA DE ALIVIO	1	82	079001001085	CONJUNTO DEL GATILLO – NO SE ILUSTR (INCL. LLAVES NÚM. 20-27)	1
9	079007001009	UNIDAD DEL IMPULSOR	1	50	079001001051	ANILLO “E” (ETW2)	3	83	079001001099	JUEGO DE LLAVE – NO SE ILUSTR (INCL. SÓLO LLAVES HEX. DE 3 Y 4 mm)	1
10	079001001010	JUNTA TÓRICA (23 x 2) (2023)	1	51	079001001052	AMORTIGUADOR DEL ELEMENTO DE CONTACTO CON LA PIEZA DE TRABAJO	1	84	079001001907	BOLSA DE HERRAMIENTAS – NO SE ILUSTR	1
11	079001001011	COLLAR	1	52	079001001053	PASADOR FIJO	1	85	079001001088	ANTEOJOS – NO SE ILUSTR	1
12	079001001012	CILINDRO	1	53	079001001054	RESORTE POSICIONAM.	1	86	079001001096	ETIQUETA DE ADVERTENCIA - NO SE ILUSTR	1
13	079001001013	JUNTA TÓRICA (32 x 2) (2032)	1	54	079001001055	TAPA GUÍA IMPULSOR	1	87	079001001095	ETIQUETA DE DATOS – NO SE ILUSTR	1
14	079001001014	ANILLO CILINDRO	1	55	079001001059	UNIDAD DEL EMPUJADOR	1	88	079001001092	ETIQUETA DE LOGOTIPO – NO SE ILUSTR	2
15	079001001015	SEPARADOR CILINDRO	1	56	079001001081	MECANISMO CONTACTO A	1	89	079001001093	ETIQUETA DE MODELO (ESTUCHE)	1
16	079001001016	JUNTA TÓRICA (47,5 x 2) (S48)	1	57	079001001090	ALMOHADILLA PROTECTORA	2	90	983000614	MANUAL DEL OPERADOR – NO SE ILUSTR	1
17	079001001017	TOPE	1	58	079001001130	* GUÍA DE JUNTURAS	1	91	983000623	GUÍA DE SUJETADORES – NO SE ILUSTR	1
18	079001001129	* GUÍA DEL IMPULSOR	1	59	079001001060	EJE	2	92	079001001102	ETIQUETA DEL GATILLO – NO SE ILUSTR	1
19	079001001019	SELLO TAPA CILINDRO	1	60	079001001061	RESORTE DEL EMPUJADOR	2	93	079001001103	ETIQUETA –NO SE ILUSTR	1
20	079001001020	SELLO	1	61	079001001062	RETÉN	1				
21	079001001021	CAB. VÁLVULA GATILLO	1	62	079001001063	CONJ. DEL PERNO (M4 x 0,7-08 + Dp4)	1				
22	079001001022	RESORTE	1	63	079001001064	TUERCA SEGURIDAD (M4 X 0,7)	2				
23	079001001023	ÉMBOLO	1	64	079001001065	PERNO (CAB. HUE. HEX) (M4 x 0,7-16)	1				
24	079001001024	JUNTA TÓRICA (2,5 x 1,5) (S3)	1	65	079001001066	PLACA TRASERA	1				
25	079001001025	JUNTA TÓRICA (2,5 x 1,5) (S3)	1	66	079001001079	UNIDAD BARRA AJUSTE	1				
26	079001001026	JUNTA TÓRICA (13 x 2) (2013)	1	67	079001001105	CARGADOR UNIDAD B CON INSERCIÓN	1				
27	079001001027	TAPA DEL ÉMBOLO	1	68	079001001077	RESORTE DEL ELEMENTO DE CONTACTO CON LA PIEZA DE TRABAJO	1				
28	079001001028	PASADOR PIVOTE GATILLO	1	69	079001001070	PESTILLO	1				
29	079001001029	RETÉN	1	70	079001001071	MUELLE DE FIJACIÓN	1				
30	079001001030	RESORTE	1	71	079001001072	PASADORES ESPIRAL (Dp3-24)	2				
31	079001001031	UNIDAD DEL GATILLO	1	72	079001001073	CUBIERTA CAPUCHA	1				
32	079007001701	* ARMAZÓN HERRAMIENTA	1	73	079001001074	PERNO (CAB. HUE. HEX) (M4 x 0,7-25)	1				
33	079001001033	JUNTA TÓRICA (7,5 x 1,5) (S8)	2	74	079007001115	PERILLA DE AJUSTE	1				
34	079001001034	VARILLA ACOPLAMIENTO	1								
35	079001001036	FILTRO	1								
36	079001001037	JUNTA	1								
37	079001001038	RETÉN DEL RESORTE	1								
38	079001001039	EJE POSICIONAM.	1								
39	079001001040	RESORTE POSICIONAM.	1								
40	079001001041	TORNILLO (CAB. HUE. HEX) (M4 x 0,7-06)	2								
41	079001001042	TAPA EXTREMO (NPT 1/4 pulg.)	1								

* Nota: Comenzar con el número de série:
AW082815576