

**RIDGID  
ANGLED FINISH NAILER  
MODEL NO. R250AFA  
REPAIR SHEET**

**RIDGID  
CLOUEUSE DE FINITION ANGULAIRE  
NO. DE MODÈLE R250AFA  
FEUILLE DE RÉPARATION**

**RIDGID  
CLAVADORA DE ACABADO ANGULAR  
MODELO R250AFA  
LISTAS DE PIEZAS DE REPUESTO**

# RIDGID® R250AFA

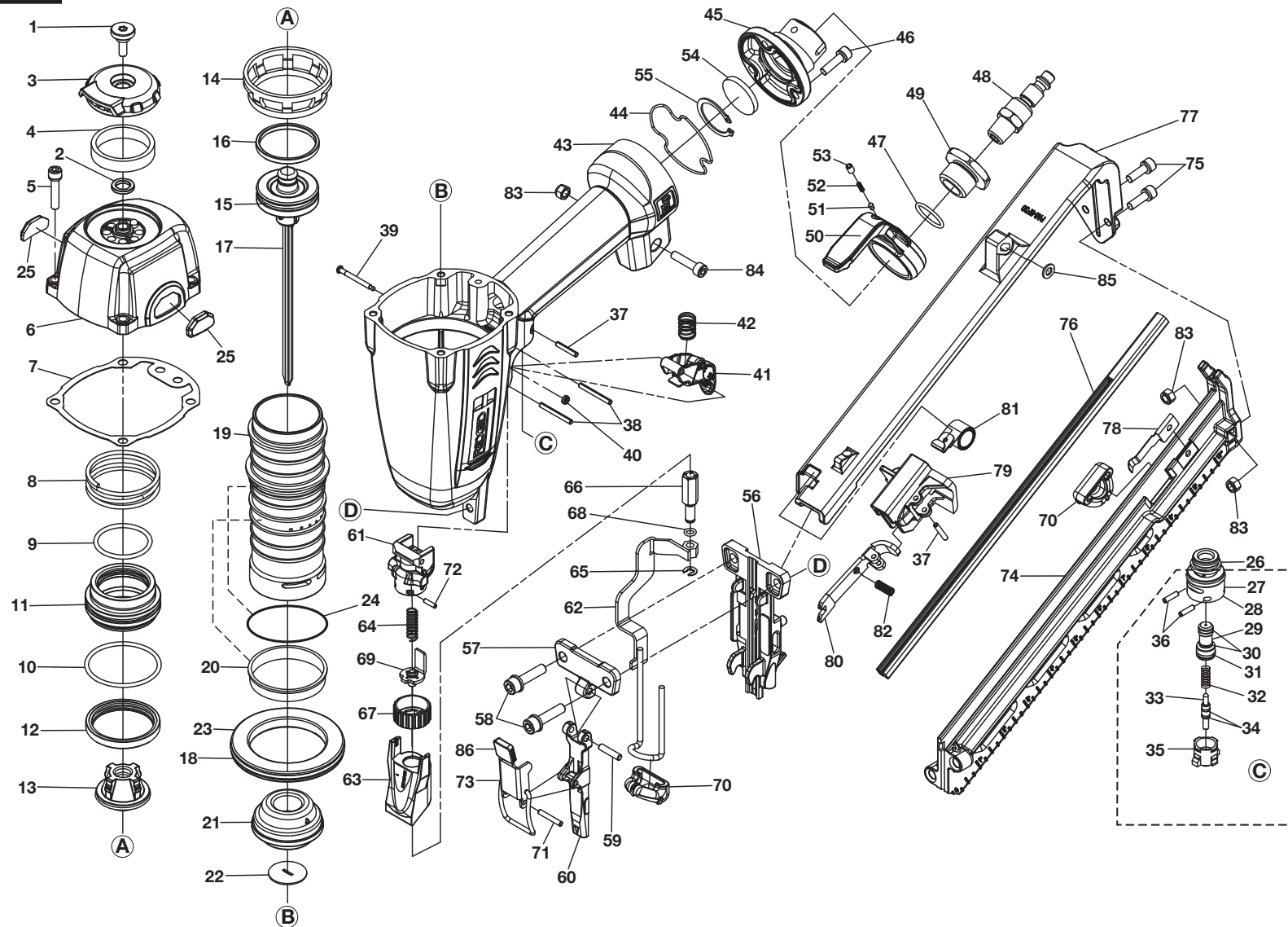

**⚠ DANGER:** Do not use oxygen, combustible gases, or bottled gases as a power source for this tool. The tool will explode and cause death or serious injury.

**⚠ DANGER :** Ne pas utiliser de l'oxygène ou des gaz combustibles ou en bouteille pour alimenter l'outil. L'outil exploserait, causant des blessures graves ou mortelles.

**⚠ PELIGRO:** No utilice oxígeno, gases combustibles ni gases embotellados como fuente de energía para esta herramienta. La herramienta explotará y causará la muerte o lesiones serias.

**⚠ WARNING:** Disconnect the tool from the air supply before performing maintenance. Failure to do so could result in serious personal injury.

**⚠ AVERTISSEMENT :** Débrancher l'outil de la source d'air avant tout entretien. Ne pas prendre cette précaution peut entraîner des blessures graves.

**⚠ ADVERTENCIA:** Desconecte la herramienta del suministro de aire antes de efectuar tareas de mantenimiento. La inobservancia de esta advertencia puede causar lesiones serias.



# R250AFA Angled Finish Nailer

KEY	P/N	DESCRIPTION	QTY	KEY	P/N	DESCRIPTION	QTY	KEY	P/N	DESCRIPTION	QTY
1	079003001002	DEFLECTOR BOLT (3M2353).....	1	45	079004001045	END CAP.....	1	82	079004001081	PUSHER SPRING .....	1
2	079003001004	RUBBER PAD.....	1	46	079004001046	BOLT ASSY (M5 x 0.8-18 + Dp5) ..	3	83	079003001081	LOCK NUT (M5 x 0.8) .....	3
3	079003001003	DEFLECTOR .....	1	47	079002001056	O-RING (19.18 x 2.46) (2019).....	1	84	079004001083	BOLT (HEX SOC. HD.) (M5 x 0.8-20) .....	1
4	079003001024	MUFFLER.....	1	48	079004001048	AIR PLUG (NPT 3/8 in.-18).....	1	85	079004001093	FLAT WASHER.....	1
5	079004001005	BOLT ASSY (M5 x 0.8-25 + Dp5) ..	4	49	079002001057	LATCH SPRING BUSHING (NPT 3/8 in.) .....	1	86	079003001062	PUSHER CUSHION .....	1
6	079004001006	CAP .....	1	50	079003001050	SPRING RETAINER.....	1	87	079004001084	OVERHAUL KIT – NOT SHOWN (INCL. KEY NO. 7, 9, 10, 12, 13, 16, 18, 20, 21, 24, 40, PLUS LUBRICANT) .....	1
7	079004001007	CYLINDER CAP SEAL.....	1	51	079001001039	POSITIONING SHAFT .....	1				
8	079004001008	COMPRESSION SPRING.....	1	52	079001001040	POSITIONING SPRING .....	1				
9	079004001009	O-RING (32.99 x 2.62) (AS125) .....	1	53	079001001041	SCREW (HEX SOC. HD.) (M4 x 0.7-06) .....	1	88	079004001085	DRIVER MAINTENANCE KIT – NOT SHOWN (INCL. KEY NO. 7, 15-17, AND 21, PLUS LUBRICANT) .....	1
10	079004001010	O-RING (44.5 x 2.5).....	1	54	079003001044	FILTER.....	1				
11	079004001011	HD.VALVE PISTON.....	1	55	079003001110	SNAP RING (IRTW28) .....	1				
12	079004001012	COLLAR .....	1	56	079004001056	DRIVER GUIDE.....	1	89	079004001086	DRIVER ASSEMBLY – NOT SHOWN ( INCL. KEY NO. 15-17 PLUS LUBRICANT) .....	1
13	079004001013	SEAL .....	1	57	079004001057	DRIVER GUIDE COVER B.....	1				
14	079004001014	PRESS RING.....	1	58	079004001058	BOLT ASSY (M6 x 1.0-25+Dp6) (3M2353) .....	2	90	079003001112	TRIGGER ASSEMBLY – NOT SHOWN (INCL. KEY NO. 26-36).....	1
15	079004001015	O-RING (33.5 x 2) (S34).....	1	59	079004001059	FIXED PIN.....	1				
16	079004001016	PISTON RING.....	1	60	079004001060	DRIVER GUIDE COVER A.....	1	91	079004001089	OIL AND WRENCH KIT – NOT SHOWN (INCL. OIL AND 4 mm AND 5 mm HEX KEYS) .....	1
17	079004001017	DRIVER UNIT .....	1	61	079004001061	WORK CONTACT ELEMENT GUIDE .....	1	92	079004001088	CASE – NOT SHOWN .....	1
18	079004001018	O-RING (64.77 x 2.62) (AS145) .....	1	62	079004001062	WORK CONTACT ELEMENT UNIT .....	1	93	079001001088	GLASSES – NOT SHOWN .....	1
19	079004001019	CYLINDER.....	1	63	079004001063	WORK CONTACT ELEMENT COVER .....	1	94	079004001099	WARNING AND DATA LABEL – NOT SHOWN .....	1
20	079004001020	CYLINDER RING.....	1	64	079003001084	WORK CONTACT ELEMENT SPRING .....	1	95	079003001107	LOGO LABEL – NOT SHOWN .....	2
21	079004001021	BUMPER .....	1	65	079003001091	E-RING (ETW4).....	1	96	079004001096	MODEL LABEL (TOOL CASE).....	1
22	079004001022	DRIVER GUIDE.....	1	66	079004001066	ADJUST ROD UNIT.....	1	97	983000610	OPERATOR'S MANUAL – NOT SHOWN .....	1
23	079004001023	CYLINDER SPACER.....	1	67	079003001086	ADJUST KNOB .....	1				
24	079004001024	O-RING (44.7 x 2.4) (P22-45) .....	1	68	079003001089	O-RING (4.5 x 1.5) (S5).....	1	98	983000610R	REPAIR SHEET – NOT SHOWN .....	1
25	079004001025	CUSHION .....	2	69	079004001069	CONTACT MECHANISM B UNIT ..	1	99	983000623	FASTENER GUIDE – NOT SHOWN .....	1
26	079002001029	O-RING (12.42 x 1.78) (AS014) .....	1	70	079004001092	NO MAR PAD .....	2				
27	079002001030	O-RING (18.72 x 2.62).....	1	71	079004001070	SPIRAL PINS (Dp3-20).....	1	100	079001001102	TRIGGER WRAP LABEL – NOT SHOWN .....	1
28	079002001031	PLUNGER CAP .....	1	72	079003001083	SPRING PIN (Dp2.5-10) .....	1				
29	079002001034	VALVE PLUNGER.....	1	73	079003001063	LOCK HANDLE UNIT .....	1	101	079004001106	HANG TAG – NOT SHOWN .....	1
30	079002001033	O-RING (5.8 x 1.9) (P6).....	2	74	079004001073	MAGAZINE A.....	1				
31	079002001032	O-RING (8.8 x 1.9) (P9).....	1	75	079004001074	BOLT ASSY (M5 x 0.8-16 + Dp5) ..	2				
32	079002001035	SPRING.....	1	76	079004001075	STEEL CHANNEL.....	1				
33	079002001037	PLUNGER .....	1	77	079004001076	MAGAZINE B .....	1				
34	079001001024	O-RING (2.5 x 1.5) (S3).....	2	78	079004001077	NAIL PLATE (STOP).....	1				
35	079002001038	TRIGGER VALVE HEAD.....	1	79	079004001078	HOOD COVER.....	1				
36	079002001039	SPRING PIN (Dp3-12) .....	2	80	079004001079	PUSHER.....	1				
37	079004001037	SPRING PIN (Dp3-18) .....	2	81	079004001080	SPRING UNIT.....	1				
38	079004001038	SPRING PIN (Dp3-28) .....	1								
39	079002001045	TRIGGER PIVOT PIN.....	1								
40	079001001029	RETAINER .....	1								
41	079002001043	TRIGGER UNIT.....	1								
42	079002001046	SPRING.....	1								
43	079004001043	TOOL BODY UNIT.....	1								
44	079004001044	GASKET .....	1								

03-28-06  
(REV: 03)



