

**RIDGID
R350FCA FRAMING COIL NAILER
REPAIR SHEET**

**RIDGID
R350FCA CLOUEUSE À BOBINE POUR
CHARPENTES
FEUILLE DE RÉPARATION**

**RIDGID
R350FCA CLAVADORA DE BOBINA
PARA ENTRAMAR
LISTAS DE PIEZAS DE REPUESTO**

RIDGID

R350FCA

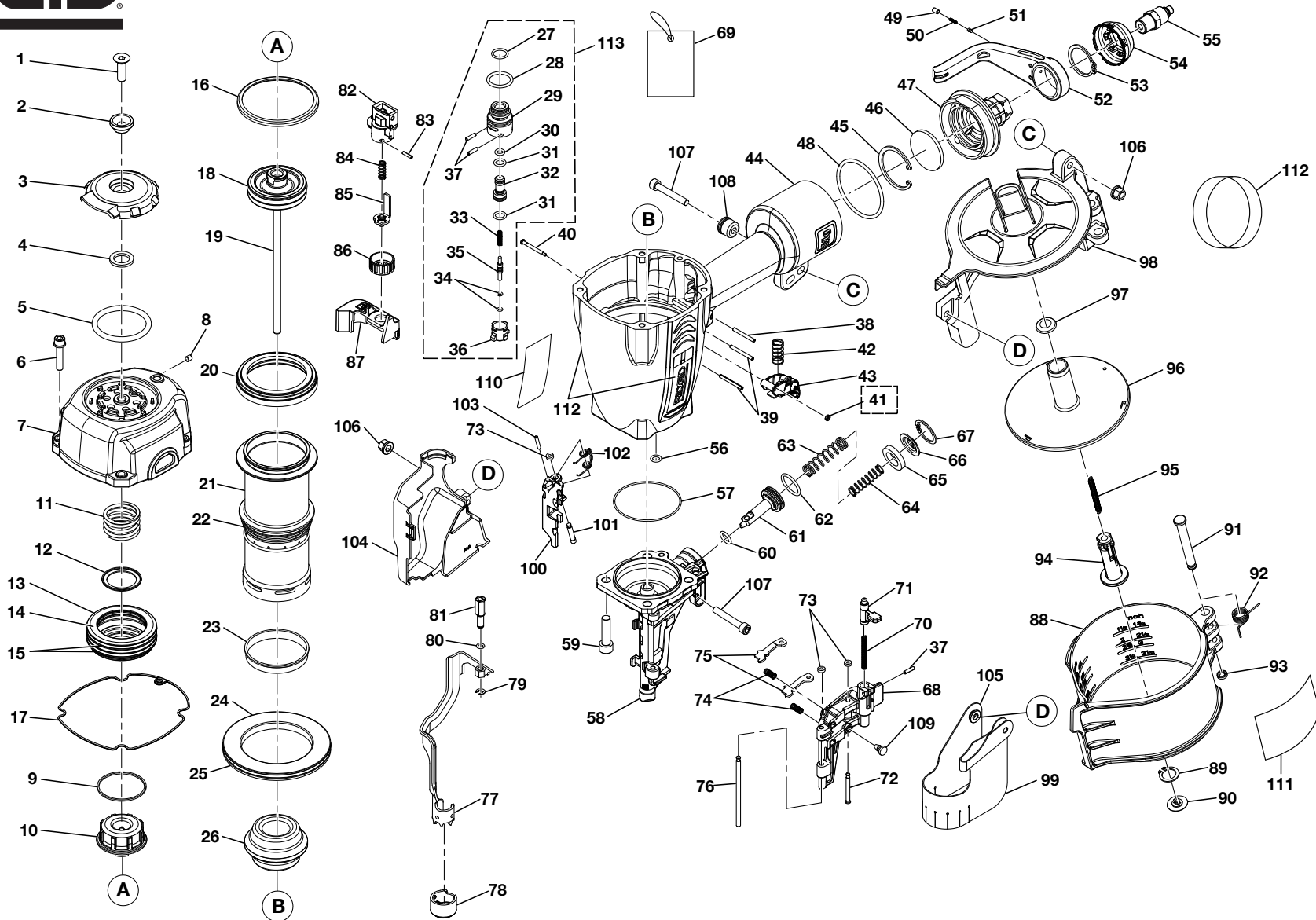

⚠ DANGER: Do not use oxygen, combustible gases or bottled gases as a power source for this tool. The tool will explode and cause death or serious injury.

⚠ DANGER : Ne pas utiliser de l'oxygène ou des gaz combustibles ou en bouteille pour alimenter l'outil. L'outil exploserait, causant des blessures graves ou mortelles.

⚠ PELIGRO: No utilice oxígeno, gases combustibles ni gases embotellados como fuente de energía para esta herramienta. La herramienta explotará y causará la muerte o lesiones serias.

⚠ WARNING: Disconnect the tool from the air supply before performing maintenance. Failure to do so could result in serious personal injury.

⚠ AVERTISSEMENT : Débrancher l'outil de la source d'air avant tout entretien. Ne pas prendre cette précaution peut entraîner des blessures graves.

⚠ ADVERTENCIA: Desconecte la herramienta del suministro de aire antes de efectuar tareas de mantenimiento. La inobservancia de esta advertencia puede causar lesiones serias.

RIDGID® R350FCA

KEY	P/N	DESCRIPTION	QTY	KEY	P/N	DESCRIPTION	QTY	KEY	P/N	DESCRIPTION	QTY
1	079002001001	SCREW (M8 x 1.25-25 mm) (COUNTER SUNK)	1	47	079020001020	END CAP	1	93	079020001054	FIXED RING.....	1
2	079002001002	DEFLECTOR PAD.....	1	48	079002001051	O-RING (56.5 x 3.1).....	1	94	079020001055	ADJUST POST	1
3	079002001003	DEFLECTOR.....	1	49	079001001041	SCREW (M4 x 0.7-06) (HEX. SOC. HD.).....	1	95	079020001056	PULL SPRING.....	1
4	079002001004	RUBBER PAD.....	1	50	079001001040	POSITIONING SPRING.....	1	96	079020001057	SPACER	1
5	079002001005	MUFFLER.....	1	51	079001001039	POSITIONING SHAFT	1	97	079020001058	SPRING BASE.....	1
6	079020001001	BOLT ASSEMBLY (M6 x 1.0-30 mm)	4	52	079002001055	SPRING RETAINER	1	98	079020001059	MAGAZINE COVER.....	1
7	079020001002	TOP CAP	1	53	079020001021	C-RING.....	1	99	079020001060	WIRE DEFLECTOR.....	1
8	079002001008	SCREW (M5 x 0.8-05 mm) (HEX. SOC. HD.).....	1	54	079020001022	COVER	1	100	079020001061	FEED FINGER.....	1
9	079020001003	GASKET	1	55	079004001048	AIR PLUG (NPT 3/8-18).....	1	101	079020001062	FEED PISTON LATCH.....	1
10	079020001004	SEAL.....	1	56	079020001023	O-RING (6.8 x 1.9).....	1	102	079020001063	FEED PISTON SPRING.....	1
11	079020001005	COMPRESSION SPRING.....	1	57	079020001024	O-RING (62.31 x 1.5).....	1	103	079020001064	SPRING PIN	1
12	079020001006	WASHER	1	58	079020001025	NOSE PIECE	1	104	079020001065	SPRING COVER.....	1
13	079020001007	O-RING (47.04 x 3.1).....	1	59	079002001068	BOLT ASSEMBLY (M8 x 1.25-30 mm)	4	105	079020001066	GASKET	1
14	079020001008	HEAD VALVE PISTON	1	60	079020001026	O-RING (9.8 x 2.4).....	1	106	079020001067	HEX NUT (M6 x 1.0)	2
15	079020001009	O-RING (61.5 x 3.1).....	2	61	079020001027	FEED PISTON	1	107	079020001068	BOLT ASSEMBLY (M6 x 1.0 x 38 mm).....	2
16	079002001019	PRESS RING.....	1	62	079020001028	O-RING (20.8 x 2.4).....	1	108	079020001069	FIXED BASE	1
17	079020001010	CYLINDER CAP SEAL.....	1	63	079020001029	FEED SPRING A.....	1	109	079020001070	WIRE DEFLECTOR BOLT.....	1
18	079020001011	O-RING (46.99 x 5.33).....	1	64	079020001030	FEED SPRING B.....	1	110	079020001072	WARNING LABEL/DATA LABEL.....	1
19	079020001012	DRIVER UNIT	1	65	079020001031	BUMPER	1	111	079002001103	LOGO LABEL	2
20	079020001013	COLLAR	1	66	079020001032	FEED PISTON CAP	1	112	079005001119	TRIGGER WRAP LABEL	1
21	079020001014	CYLINDER	1	67	079020001033	C-RING.....	1	113	079020001081	TRIGGER VALVE ASSEMBLY (INCLUDES KEY NOS. 27-37 AND 41 AND INSTRUCTIONS. AVAILABLE AS AN ASSEMBLY ONLY.)	1
22	079020001015	O-RING (62 x 3).....	1	68	079020001034	DOOR.....	1	NOT SHOWN			
23	079002001027	CYLINDER RING.....	1	69	079020001073	HANG TAG	1	114	079002001097	TOOL BAG	1
24	079002001025	CYLINDER SPACER.....	1	70	079020001035	LATCH SPRING.....	1	115	079002001099	EYE PROTECTION	1
25	079020001016	O-RING (97.9 x 3.1).....	1	71	079020001036	LATCH	1	116	079020001074	WRENCH KIT (5 mm/6 mm) WITH LUBRICANT	1
26	079020001017	BUMPER	1	72	079020001037	NAIL PRESS LATCH.....	1	117	987000033	OPERATOR'S MANUAL.....	1
27	079002001029	O-RING (12.42 x 1.78).....	1	73	079020001038	RETAINER	3	118	079020001076	FASTENER GUIDE	1
28	079002001030	O-RING (18.72 x 2.62).....	1	74	079020001039	STOPPER FINGER SPRING.....	2	119	079020001078	OVERHAUL MAINTENANCE KIT (INCLUDES KEY NOS. 13, 15, 17, 18, 20, 22, 23, 25, 26, 41, 113, INSTRUCTION SHEET AND LUBRICANT)	1
29	079002001031	PLUNGER CAP	1	75	079020001040	STOPPER FINGER.....	2	120	079020001079	DRIVER MAINTENANCE KIT (INCLUDES KEY NOS. 17, 18, 19, AND 26, INSTRUCTION SHEET AND LUBRICANT).....	1
30	079002001032	O-RING (8.8 x 1.9) (P9).....	1	76	079020001041	DOOR LATCH.....	1	121	079020001080	DRIVER ASSEMBLY KIT (INCLUDES KEY NOS. 18 AND 19, INSTRUCTION SHEET AND LUBRICANT)	1
31	079002001033	O-RING (5.8 x 1.9) (P6).....	2	77	079020001042	WORKPIECE CONTACT A	1	8-09-07 (REV: 00)			
32	079020001018	VALVE PLUNGER.....	1	78	079020001043	NO MAR PAD	1				
33	079002001035	SPRING	1	79	079003001091	CLIP (ETW6).....	1				
34	079001001024	O-RING (2.5 x 1.5) (S3).....	2	80	079003001089	O-RING (4.5 x 1.5).....	1				
35	079002001037	PLUNGER	1	81	079020001044	ADJUST ROD UNIT.....	1				
36	079002001038	TRIGGER VALVE HEAD.....	1	82	079020001045	WORKPIECE CONTACT GUIDE.....	1				
37	079002001039	SPRING PIN (3-12).....	3	83	079003001083	SPRING PIN	1				
38	079002001041	SPRING PIN (3-25).....	1	84	079003001084	WORKPIECE CONTACT SPRING	1				
39	079002001040	SPRING PIN (3-30).....	2	85	079020001046	WORKPIECE CONTACT B ASSEMBLY	1				
40	079002001045	TRIGGER PIVOT PIN.....	1	86	079020001047	ADJUST SHAFT	1				
41	079001001029	RETAINER	1	87	079020001048	WORKPIECE CONTACT COVER	1				
42	079002001046	SPRING.....	1	88	079020001700	MAGAZINE CASE WITH WARNING / DATA LABEL.....	1				
43	079002001043	TRIGGER UNIT.....	1	89	079020001050	C-RING.....	1				
44	079020001019	TOOL BODY HOUSING	1	90	079020001051	SPRING BASE.....	1				
45	079002001048	C-RING (RTW42).....	1	91	079020001052	PIN.....	1				
46	079002001049	FILTER.....	1	92	079020001053	SPRING	1				

PIÈCE	RÉF.	DESCRIPTION	QTÉ	PIÈCE	RÉF.	DESCRIPTION	QTÉ	PIÈCE	RÉF.	DESCRIPTION	QTÉ
1	079002001001	VIS (NOYÉE) (M8 x 1,25-25 mm).....	1	47	079020001020	CAPUCHON D'EXTRÉMITÉ.....	1	90	079020001051	BASE DE RESSORT.....	1
2	079002001002	COUSSINET DE DÉFLECTEUR.....	1	48	079002001051	JOINT TORIQUE (47,8 x 2,62).....	1	91	079020001052	GOUPILLE.....	1
3	079002001003	DÉFLECTEUR.....	1	49	079001001041	VIS (M4 x 0,7-06) (6 PANS, TÊTE CREUSE)...	1	92	079020001053	RESSORT.....	1
4	079002001004	COUSSINET EN CAOUTCHOUC.....	1	50	079001001040	RESSORT DE POSITIONNEMENT.....	1	93	079020001054	BAGUE FIXE.....	1
5	079002001005	SILENCIEUX.....	1	51	079001001039	EJE POSICIONAM.....	1	94	079020001055	TIGE DE RÉGLAGE.....	1
6	079020001001	BOULON (M6 x 1,0-30 mm).....	4	52	079002001055	RETENUE DE RESSORT.....	1	95	079020001056	RESSORT DE TRACTION.....	1
7	079020001002	COUVERCLE.....	1	53	079020001021	CLIP EN C (STW30).....	1	96	079020001057	PIÈCE D'ÉCARTEMENT.....	1
8	079002001008	VIS (6 PANS TÊTE CREUSE) (M5 x 0,8-05 mm).....	1	54	079020001022	COUVERCLE DE CAPOT.....	1	97	079020001058	BASE DE RESSORT.....	1
9	079020001003	GARNITURE.....	1	55	079004001048	BOUCHON D'AIR (NPT 3/8-18).....	1	98	079020001059	BOÎTIER DU MAGASIN.....	1
10	079020001004	JOINT.....	1	56	079020001023	JOINT TORIQUE (6,8 x 1,9).....	1	99	079020001060	DÉFLECTEUR D'ÉCLATS.....	1
11	079020001005	RESSORT DE COMPRESSION.....	1	57	079020001024	JOINT TORIQUE (62,31 x 1,5).....	1	100	079020001061	DOIGT D'ALIMENTATION.....	1
12	079020001006	RONDELLE.....	1	58	079020001025	TÊTE.....	1	101	079020001062	LOQUET DU PISTON DE CHARGEMENT.....	1
13	079020001007	JOINT TORIQUE (47,04 x 3,1).....	1	59	079002001068	BOULON (M6 x 1,0-30 mm).....	4	102	079020001063	RESSORT DE PISTON D'ALIMENTATION.....	1
14	079020001008	PISTON DE SOUPE.....	1	60	079020001026	JOINT TORIQUE (9,8 x 2,4).....	1	103	079020001064	GOUPILLE ÉLASTIQUE.....	1
15	079020001009	JOINT TORIQUE (61,5 x 3,1).....	2	61	079020001027	PISTON DE CHARGEMENT.....	1	104	079020001065	TAPA DE LA RESSORT.....	1
16	079002001019	ANNEAU DE PRESSION.....	1	62	079020001028	JOINT TORIQUE (20,8 x 2,4).....	1	105	079020001066	GARNITURE.....	1
17	079020001010	JOINT DU COUVRCLE DE CYLINDRE.....	1	63	079020001029	RESSORT D'ALIMENTATION A.....	1	106	079020001067	ÉCROU HEXAGONAL (M6 x 10).....	2
18	079020001011	JOINT TORIQUE (46,99 x 5,33).....	1	64	079020001030	RESSORT D'ALIMENTATION B.....	1	107	079020001068	BOULON (M6 x 10 x 38 mm).....	1
19	079020001012	ENTRAÎNEMENT.....	1	65	079020001031	ANNEAU DE CYLINDRE.....	1	108	079020001069	BASE FIXE.....	1
20	079020001013	COLLIER.....	1	66	079020001032	CAPUCHON DE PISTON D'ALIMENTATION.....	1	109	079020001070	DÉFLECTEUR D'ÉCLATS BOULON.....	1
21	079020001014	CYLINDRE.....	1	67	079020001033	CLIP EN C (RTW42).....	1	110	079020001072	AUTOCOLLANT D'AVERTISSEMENT/ PLAQUETTE SIGNALÉTIQUE.....	1
22	079020001015	JOINT TORIQUE (62 x 3).....	1	68	079020001034	PORTE.....	1	111	079002001103	PLAQUETTE DE LOGO.....	2
23	079002001027	ANNEAU DE CYLINDRE.....	1	69	079020001073	ÉTIQUETTE.....	1	112	079005001119	AUTOCOLLANT DE GÂCHETTE.....	1
24	079002001025	PIÈCE D'ÉCARTEMENT.....	1	70	079020001035	LOQUET RESSORT.....	1	113	079020001081	SOUPE DE DÉCLENCHEMENT - (INCLUT PIÈCES DE REPÈRE 27 À 37, ET 41 ET FEUILLE D'INSTRUCTION. DISPONIBLE COMME UN ENSEMBLE SEULEMENT).....	1
25	079020001016	JOINT TORIQUE (97,9 x 3,1).....	1	71	079020001036	LOQUET.....	1				
26	079020001017	BUTOIR.....	1	72	079020001037	LOQUET DE PRESSION DU CLOU.....	1				
27	079002001029	JOINT TORIQUE (12,42 x 1,78).....	1	73	079020001038	RETENUE.....	3				
28	079002001030	JOINT TORIQUE (18,72 x 2,62).....	1	74	079020001039	RESSORT DE DOIGT D'ARRÊT.....	2				
29	079002001031	COUVERCLE DE PLONGEUR.....	1	75	079020001040	RESSORT DE DOIGT.....	2				
30	079002001032	JOINT TORIQUE (8,8 x 1,9).....	1	76	079020001041	PESTILLO PUERTA.....	1				
31	079002001033	JOINT TORIQUE (5,8 x 1,9).....	2	77	079020001042	CONTACT DE DÉCLENCHEMENT A.....	1				
32	079020001018	PLONGEUR DE SOUPE.....	1	78	079020001043	COUSSINET DE PROTECTION.....	1				
33	079002001035	RESSORT.....	1	79	079003001091	AGRAFE (ETW6).....	1				
34	079001001024	JOINT TORIQUE (2,5 x 1,5) (S3).....	2	80	079003001089	JOINT TORIQUE (4,5 x 1,5).....	1				
35	079002001037	COUVERCLE DE PLONGEUR.....	1	81	079020001044	TIGE DE RÉGLAGE.....	1				
36	079002001038	TÊTE DE SOUPE DE DÉCLENCHEMENT.....	1	82	079020001045	GUIDE DU CONTACT.....	1				
37	079002001039	GOUPILLE ÉLASTIQUE (3-12).....	3			DE DÉCLENCHEMENT.....	1				
38	079002001041	GOUPILLE ÉLASTIQUE (3-25).....	1	83	079003001083	GOUPILLE ÉLASTIQUE.....	1				
39	079002001040	GOUPILLE ÉLASTIQUE (3-30).....	2	84	079003001084	RESSORT DU CONTACT DE DÉCLENCHEMENT.....	1				
40	079002001045	AXE PIVOT DE GÂCHETTE.....	1			CONTACT DE DÉCLENCHEMENT A.....	1	120	079020001079	KIT D'ENTRETIEN DU MÉCANISME D'ENTRAÎNEMENT (INCLUT PIÈCES DE REPÈRE 17, 18, 19 ET 26, FEUILLE D'INSTRUCTION ET LE LUBRIFIANT).....	1
41	079001001029	RETENUE.....	1	85	079020001046	CONTACT DE DÉCLENCHEMENT A.....	1				
42	079002001046	RESSORT.....	1	86	079020001047	AJUSTEMENT DE LA GAINÉ.....	1				
43	079002001043	GÂCHETTE.....	1	87	079020001048	COUVERCLE DU CONTACT DE DÉCLENCHEMENT.....	1				
44	079020001019	CORPS DE L'OUTIL.....	1			BOÎTIER DU MAGASIN AVEC AUTOCOLLANT D'AVERTISSEMENT ET DE SIGNALÉTIQUE.....	1	121	079020001080	MÉCANISME D'ENTRAÎNEMENT (INCLUT PIÈCES DE REPÈRE 18 ET 19, FEUILLE D'INSTRUCTION ET LE LUBRIFIANT).....	1
45	079002001048	CLIP EN C (RTW42).....	1	88	079020001700	BOÎTIER DU MAGASIN AVEC AUTOCOLLANT D'AVERTISSEMENT ET DE SIGNALÉTIQUE.....	1				
46	079002001049	ÉLÉMENT FILTRANT.....	1	89	079020001050	CLIP EN C (RTW42).....	1				

